

#### PRODUCT HIGHLIGHTS

- Plant floor interface for Real-time inventory management, Remote process monitoring, HVAC & energy management, environmental monitoring, low cost OEM applications
- Ideal for ID tag applications, serial ports link to code readers
- Datalogging and timestamping trending, alarm logging, & transaction recording
- Stand alone control of remote sites, IEC 61131 ISaGRAF and also C++ programming via open source Linux
- Limitless multi-user connectivity telephone, Internet, and wireless telemetry, 10/100 Ethernet plus up to 4 com ports
- Embedded Linux open source software, add applications, I/O drivers & much more
- An OEM's dream platform, pre-certified, add your application

#### PERFORMANCE SPECIFICATIONS

- Industrial PowerPC (32 bit data bus)
- Operating system embedded open-source Linux
- Dynamic memory (RAM) 16 Mbytes for program execution, dynamic variables, dynamic file system, etc.
- Program memory (Flash) 16 Mbytes for Linux OS, program storage and file system
- Retained memory (RAM) 512K (battery-backed) for datalogging and retained variables
- Real-time clock battery-backed for time stamping and other operations
- Local I/O (on-board) 12 or 14 (see ordering info.)
- I/O Expansion (up to 256) RS485 or Ethernet
- Datalogging support
- IEC 61131 programming, ISaGRAF for ladder logic, SFC, flow charting and more (6 languages supported)
- High Level C programming

#### ETHERNET PORT

- 10/100BaseTx (auto-detecting)
- RJ45 connection (auto-crossover)
- Protocols TCP/IP, ARP, UDP, ICNP, DHCP, Modbus/TCP, Sixnet, optionally PPP, DNP3, IEC60870-5-101/104 and more

#### SERIAL PORT

- Up to 115,200 baud
- RS485 Port A screws (485+, 485-, GND) (2-wire half-duplex)
- RS232 Port B RJ45 (TD, RD, CTS, RTS, CD, DTR, DSR, GND)
- RS232 Port C Screws (TD, RD, RTS, GND)
- RS232 Port D (optional) Screws (TD, RD, GND) – In place of the two analog inputs
- Protocols Master & slave modes; Sixnet & Modbus RTU/ASCII; optional: Slave; DNP3, IEC60870-5-101/104. Others available as Linux applications

#### DISCRETE INPUTS

- 8 channels sourcing or sinking (jumper/software selectable)
- Guaranteed ON voltage 9 VDC (The threshold is factory adjustable to turn on at a lower voltage – contact Sixnet)
- Maximum voltage 30 VDC
- Guaranteed OFF voltage 5.0 VDC & 1.5 mA DC
- Input resistance & current 10K Ohms and 3 mA @ 24 VDC

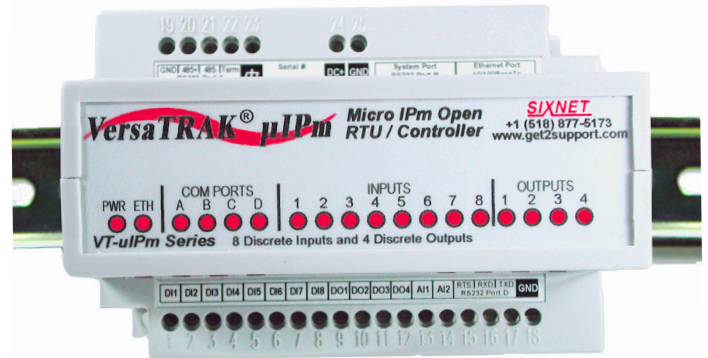

- Filtered ON/OFF delay 25 mS (20 Hz max. counting) for contact bounce filtering
- Fast ON/OFF delay 4 mS (100 Hz max. counting)
- Count rate (see above) (10 KHz on channel 1 only)
- Counter modes pulse, rate and run time
- Poll time (all channels) 5 mS to 20 mS configuration dependent

#### DISCRETE OUTPUTS

- 4 channels – sourcing 10-30 VDC
- Min. & max. output load 1 mA to 1 Amp sourcing per channel
- Max. OFF state leakage 0.05 mA
- Inrush current 5 Amps (100 mS surge)
- Typical ON characteristics 0.3 Ohms resistance and 0.3 VDC voltage drop @ 1A
- Poll time (all channels) 5 mS to 20 mS configuration dependent

#### ANALOG INPUTS

- 2 channels – current or voltage selectable
- Full scale range 4-20 mA or 0-5 VDC (jumper selectable)
- A/D and input resolution 16 bits (0.003%); 2 uA (current range) or 0.5 mV (voltage range)
- Full scale accuracy +/-0.1% (@20°C) (factory calibration)
- Span & offset temp. coeff. +/-50 ppm per °C
- Input impedance 100 Ohm (current range), 80 K Ohm voltage
- Current protection Self-resetting fuses (for 4-20 mA range)
- DMRR 66 dB at 50/60 Hz (differential mode rejection)
- CMRR (common mode rejection) Not applicable since analog inputs are single ended.
- Fastest update time 50 mS (both channels) – configurable for longer integration times for better noise filtering

#### ENVIRONMENTAL

- DIN rail or flat panel mount
- Input power 10-30 VDC
- Input current 100 mA @ 24 VDC (typical)
- Temperature -40 to 70°C (-40 to 85°C storage)
- Humidity 5% to 95% RH (non-condensing)
- Flammability UL 94V-0 materials
- Electrical safety UL 508, CSA C22.2/14; EN610101; (IEC1010)
- EMI emissions FCC part 15, ICES-003, Class A; EN55022; EN61326-1
- EMC immunity EN61326-1 (EN61000-4-2,3,4,6)
- Vibration IEC68-2-6000
- Hazardous locations (Class 1, Div 2, Groups A,B,C,D) UL 1604, CSA C22.2/213, Cenelec EN50021 Zone 2

All specifications are subject to change. Consult factory for latest info.

**MECHANICAL DIMENSIONS**

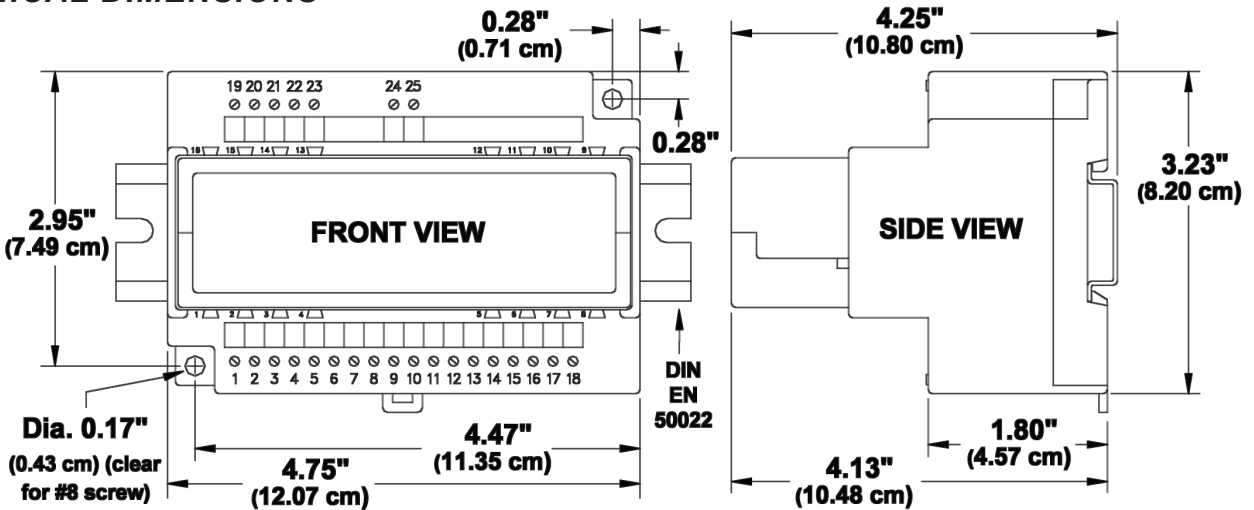

**WIRING**

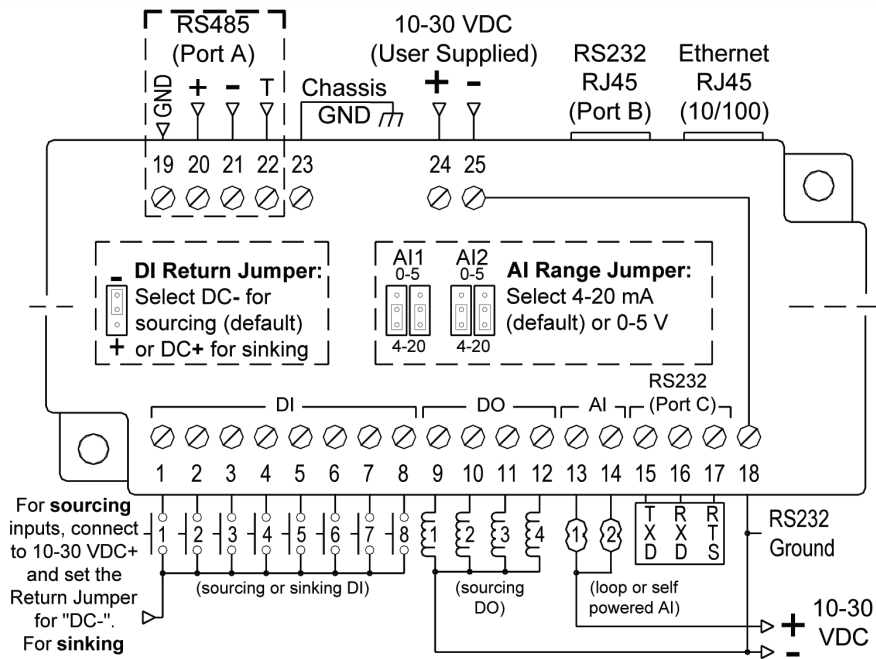

**VT-UIPM-431 with 8 DI, 4 DO, 2 AI, 1 RS485 & 2 RS232**

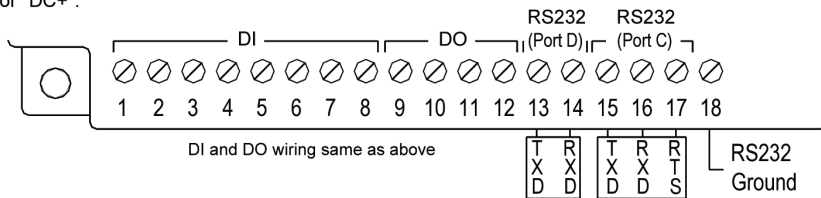

**VT-UIPM-441 with 8 DI, 4 DO, 1 RS485 & 3 RS232**

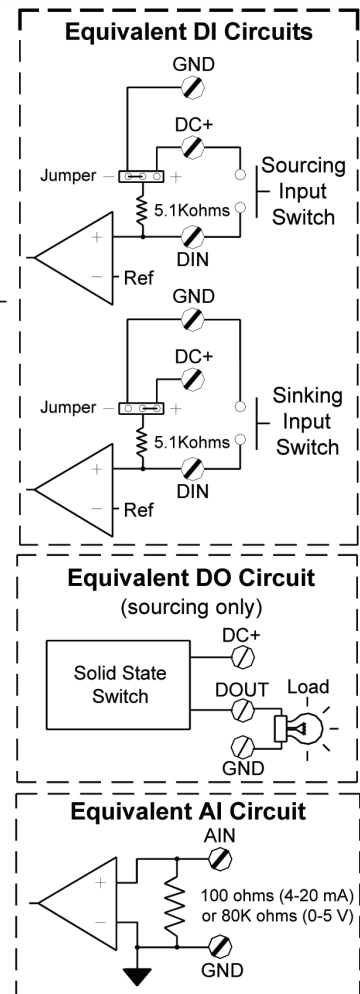

**ORDERING INFORMATION**

Model	DI	DO	AI	RS232	RS485	Ethernet
VT-UIPM-431-H	8	4	2	2	1	10/100
VT-UIPM-441-H	8	4	0	3	1	10/100



Sixnet Technology Park  
 331 Ushers Road • Ballston Lake, NY 12019 • USA  
 1.518.877.5173 • Fax 1.518.877.8346 • sales@sixnet.com

Datasheet VT-UIPM